

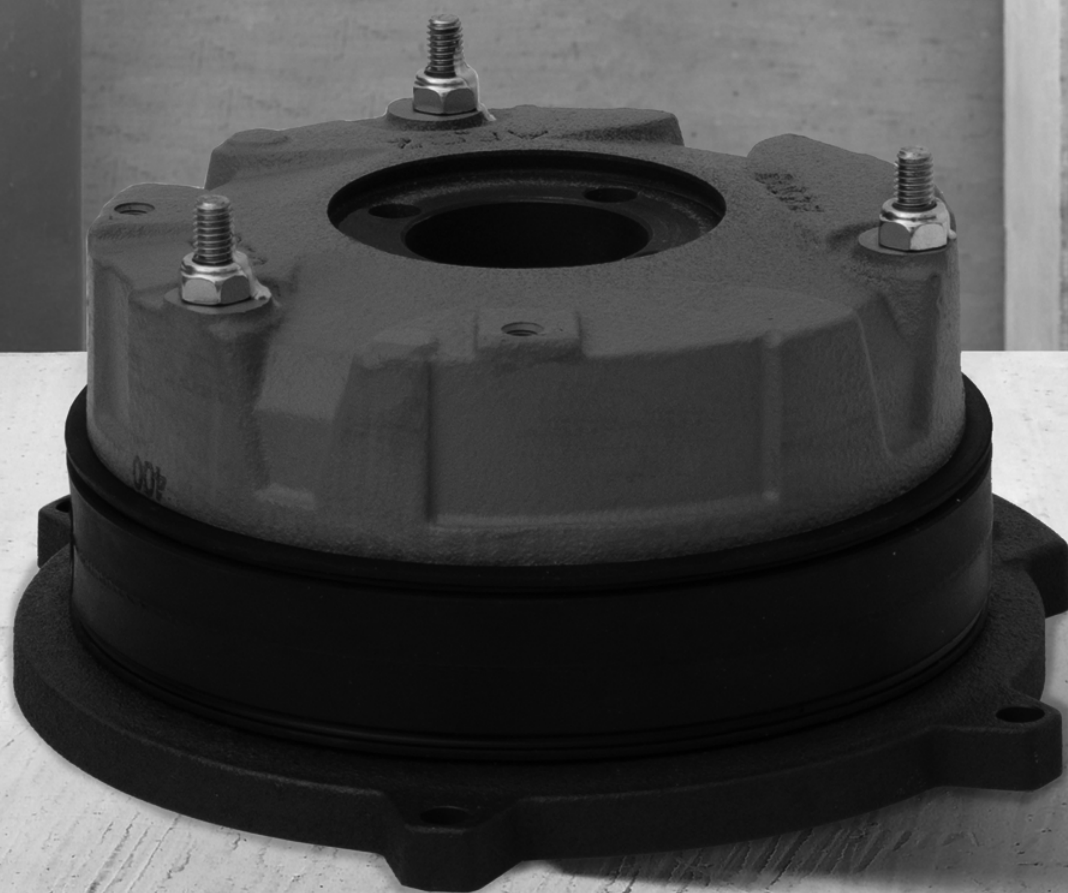

SEW
EURODRIVE



Repair Kit
BE05 – BE30 Brakes



1 Repair Kit for BE05 – BE30 Brakes

1.1 General information

1.1.1 Use of this documentation

The documentation is an integral part of the product and contains important information on service. The documentation is written for all employees who service this product.

The documentation must be accessible and legible. Make sure that persons responsible for the system and its operation, as well as persons who work independently on the unit, have read through the documentation carefully and understood it. If you are unclear about any of the information in this documentation, or if you require further information, contact SEW-EURODRIVE.

1.1.2 Structure of the safety notes

Meaning of signal words

The following table shows the grading and meaning of the signal words for safety notes, warnings regarding potential risks of damage to property, and other notes.

Signal word	Meaning	Consequences if disregarded
▲ DANGER	Imminent danger	Severe or fatal injuries
▲ WARNING	Possible dangerous situation	Severe or fatal injuries
▲ CAUTION	Possible dangerous situation	Minor injuries
NOTICE	Possible damage to property	Damage to the drive system or its environment
INFORMATION	Useful information or tip: Simplifies the handling of the drive system.	

Structure of the section safety notes

Section safety notes do not apply to a specific action but to several actions pertaining to one subject. The symbols used either indicate a general hazard or a specific hazard.

This is the formal structure of a section safety note:



▲ SIGNAL WORD

Type and source of danger.

Possible consequence(s) if disregarded.

- Measure(s) to prevent the danger.

1.1.3 Rights to claim under warranty

A requirement of fault-free operation and fulfillment of any rights to claim under limited warranty is that you adhere to the information in the documentation. Therefore read the documentation before you start working with the unit.

1.1.4 Exclusion of liability

You must comply with the information contained in this documentation to ensure safe operation and to achieve the specified product characteristics and performance features. SEW-EURODRIVE assumes no liability for injury to persons or damage to equipment or property resulting from non-observance of these operating instructions. In such cases, any liability for defects is excluded.



1.1.5 Product names and trademarks

All product names in this documentation are trademarks or registered trademarks of their respective titleholders.

1.1.6 Copyright

© 2013 – SEW-EURODRIVE. All rights reserved.

Unauthorized duplication, modification, distribution or any other use of the whole or any part of this documentation is strictly prohibited.

1.2 Safety notes

1.2.1 Preliminary information

The following basic safety notes must be read carefully to prevent injury to persons and damage to property. The operator must ensure that the basic safety notes are read and adhered to. Make sure that persons responsible for the system and its operation, as well as persons who work independently on the unit, have read through the operating instructions carefully and understood them. If you are unclear about any of the information in this documentation, or if you require further information, please contact SEW-EURODRIVE.

Please also observe the supplementary safety notes in the individual chapters of this documentation.

1.2.2 Target group

Any mechanical work may only be performed by adequately qualified personnel. Qualified personnel in the context of this documentation are persons familiar with the design, mechanical installation, troubleshooting and servicing of the product who possess the following qualifications:

- Training in mechanical engineering, e.g. as a mechanic or mechatronics technician (final examinations must have been passed).
- They are familiar with this documentation.

In addition to that, they must be familiar with the relevant safety regulations and laws, especially with the requirements of the performance levels according to DIN EN ISO 13849-1 and all other standards, directives and laws specified in this documentation. The above mentioned persons must have the authorization expressly issued by the company to operate, program, configure, label and ground units, systems and circuits in accordance with the standards of safety technology.

1.2.3 Designated use

The repair kit for BE05 – BE30 brakes is intended for installation in DR. motors.

Technical data and information on the connection conditions are provided on the nameplate and in the documentation. Always comply with the data and conditions.

1.2.4 Other applicable documentation

The following publications and documents have to be observed as well:

- "DR.71 – 315 AC Motors" operating instructions



1.3 Structure

1.3.1 Content of repair kit

The repair kit for brakes contains the following parts:

[49]	Pressure plate	[67]	Counter spring / setting sleeve
[50]	Brake spring (normal)	[68]	Brake disk
[61]	Hex nut	[69]	Circular spring
[63]	Pole sheet for 20 Nm	[73]	Brake disk
[65]	Pressure ring	[276]	Brake spring (blue)
[66]	Sealing strip	[718]	Damping plate

1.3.2 Structure of the brakes

BE05 – BE2 (DR.71 – DR.80)

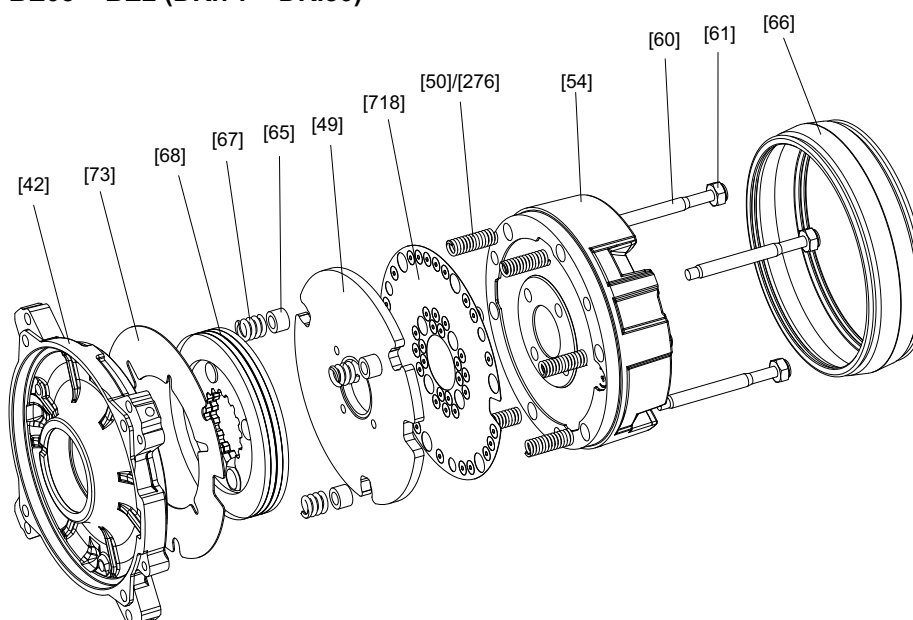

BE1 – BE11 (DR.90 – DR.160)

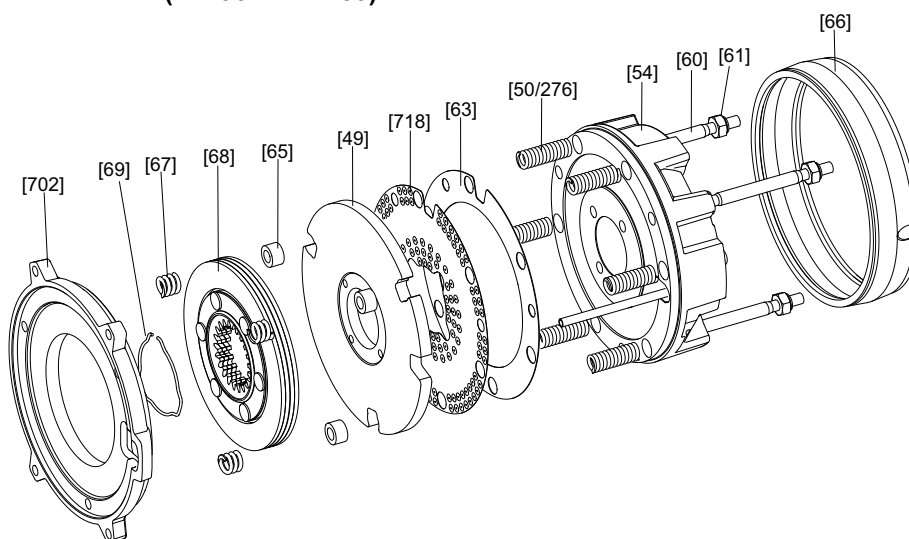



BE20 (DR.160 – DR.180)

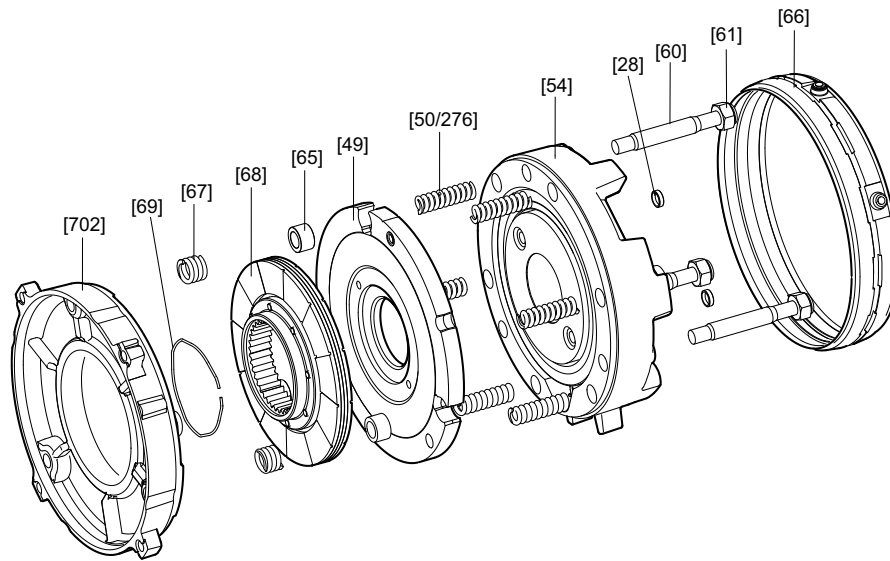

BE30 (DR.180 – DR.225)

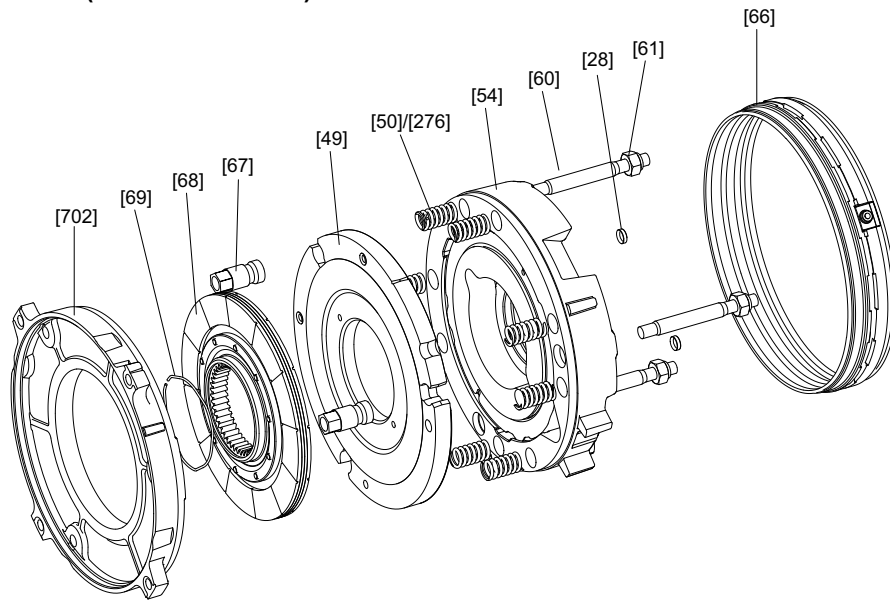

Key:

- | | | |
|-------------------------------|--------------------------------------|---------------------------|
| [28] Closing cap | [61] Hex nut | [69] Circular spring |
| [42] Brake endshield | [63] Pole sheet | [73] Brake disk |
| [49] Pressure plate, complete | [65] Pressure ring | [276] Brake spring (blue) |
| [50] Brake spring (normal) | [66] Rubber sealing collar | [702] Friction disk |
| [54] Magnet, complete | [67] Counter spring / setting sleeve | [718] Damping plate |
| [60] Stud 3x | [68] Brake disk | |



1.4 Installation work



⚠ WARNING

Risk of crushing if the drive starts up unintentionally.

Severe or fatal injuries.

- Isolate the motor, brake, and forced cooling fan, if installed, from the power supply before starting work, safeguarding them against unintentional re-start.
- Carefully observe the steps described below.

1.4.1 Setting the working air gap of BE05 – BE30 brakes

1. Remove the following:
 - Forced cooling fan and incremental encoder (if installed)
See chapter "Motor and brake maintenance – preliminary work" in the "DR.71 – 315 AC Motors" operating instructions.
 - Flange cover or fan guard [35]
2. Push the rubber sealing collar [66] aside,
 - release the clamping strap, if necessary
 - Sucking off any abrasion
3. Measure the brake disk [68]:
 - Minimum brake disk thickness, see chapter "Technical Data" in the "DR.71 – 315 AC Motors" operating instructions.
 - Replace brake disk if necessary, see chapter "Replacing the brake disk of BE05 – BE30 brakes".
4. **BE30:** Unfasten the setting sleeves [67] by turning them towards the brake end-shield.
5. Measure the working air gap A (see the following figure)
(use a feeler gauge and measure at three points offset by 120°):
 - **for BE05 – 11:** between the pressure plate [49] and damping plate [718]
 - **for BE20 – 30:** between the pressure plate [49] and brake coil body [54]

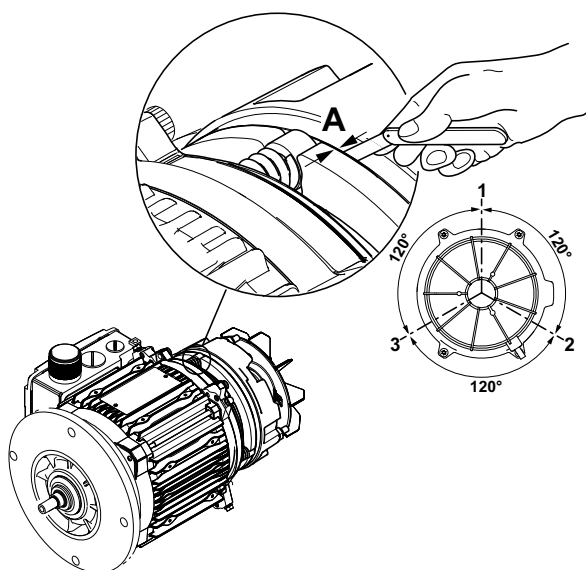

179978635



6. **BE050 – BE20:** Tighten the hex nuts [61] until the working air gap is set correctly, see chapter "Technical Data".
BE30: Tighten the hex nuts [61] until the working air gap is 0.25 mm.
7. **BE30:** Tighten the setting sleeves [67]
 - towards the magnet
 - until the working air gap is set correctly, see chapter "Technical Data" in the "DR.71 – 315 AC Motors" operating instructions.
8. Put the rubber sealing collar back in place and re-install the dismantled parts.

1.4.2 Replacing the brake disk of BE05 – BE30 brakes

Also check the hex nut nuts [61] for wear and replace them if required when you are replacing the brake disk and checking the brake elements. You must always replace the hex nuts [61] when you replace the brake disk.



INFORMATION

- The brake of DR.71-DR.80 motor sizes cannot be removed from the motor because the BE brake is directly installed on the brake endshield of the motor.
- The brake of DR.90 – DR.225 motor sizes cannot be removed from the motor for replacing the brake disk because the BE brake is pre-installed on the brake endshield of the motor with a friction disk .

1. Remove the following:
 - Forced cooling fan and incremental encoder (if installed)
See chapter "Motor and brake maintenance – preliminary work" in the "DR.71 – 315 AC Motors" operating instructions.
 - Flange cover or fan guard [35], circlip [32/62] and fan [36]
2. Remove the brake cable
 - **BE05 – BE11:** Remove the terminal box cover and unfasten the brake cable from the rectifier.
 - **BE20 – BE30:** Loosen safety screws of the brake plug connector [698] and remove plug connector.
3. Remove the rubber sealing collar [66]
4. Loosen hex nuts [61], carefully pull off the magnet [54] (brake cable!) and take out the brake springs [50].
5. **BE05 – BE11:** Remove the damping plate [718], pressure plate [49] and brake disk [68]
BE20, BE30: Remove pressure plate [49] and brake disk [68]
6. Clean the brake components
7. Install new brake disk(s).
8. Re-install the brake components,
 - Leave out the fan and the fan guard, because the working air gap has to be set first, see chapter "Setting the working air gap of the BE05 – BE30 brakes".
9. In case of manual brake release: Use the setting nuts to adjust the floating clearance "s" between the conical coil springs (pressed flat) and the setting nuts (see following figure).



Repair Kit for BE05 – BE30 Brakes

Installation work

This floating clearance "s" is necessary so that the pressure plate can move up as the brake lining wears. Otherwise, reliable braking is not guaranteed.

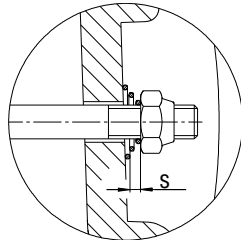

177241867

Brake	Floating clearance s [mm]
BE05, BE1, BE2, BE5	1.5
BE11, BE20, BE30	2

10. Put the rubber sealing collar back in place and re-install the dismantled parts.



INFORMATION

Important: After replacing the brake disk, the maximum braking torque is reached only after several cycles.

1.4.3 Changing the braking torque of brakes BE05 – BE30

The braking torque can be altered in stages.

- By changing the type and number of brake springs
- By changing the complete magnet (only possible for BE05 and BE1)
- By changing the brake (from motor size DR.90).
- By changing to a two-disk brake (BE30 only)

For braking torque steps, see chapter "Technical Data".



1.4.4 Changing the brake spring of BE05 – BE30 brakes

1. Remove the following:
 - Forced cooling fan and incremental encoder (if installed)
See chapter "Motor and brake maintenance – preliminary work" in the "DR.71 – 315 AC Motors" operating instructions.
 - Flange cover or fan guard [35], circlip [32/62] and fan [36]
2. Remove the brake cable
 - **BE05 – BE11:** Remove the terminal box cover and unfasten the brake cable from the rectifier.
 - **BE20 – BE30:** Loosen safety screws of the brake plug connector [698] and remove plug connector.
3. Remove the rubber sealing collar [66] and the manual brake release:
 - Setting nuts [58], conical coil springs [57], studs [56], releasing lever [53], spiral dowel pin [59]
4. Unfasten hex nuts [61] and pull off the magnet [54]
 - By approx. 50 mm (watch the brake cable)
5. Change or add brake springs [50/276]
 - Arrange brake springs symmetrically
6. Re-install the brake components
 - Leave out the fan and the fan guard, because the working air gap has to be set first, see chapter "Setting the working air gap of the BE05 – BE30 brakes".
7. In case of manual brake release: Use the setting nuts to adjust the floating clearance "s" between the conical coil springs (pressed flat) and the setting nuts (see following figure).

This floating clearance "s" is necessary so that the pressure plate can move up as the brake lining wears. Otherwise, reliable braking is not guaranteed.

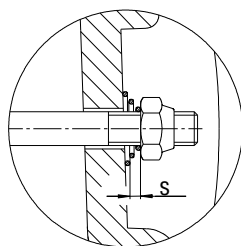

177241867

Brake	Floating clearance s [mm]
BE05, BE1, BE2, BE5	1.5
BE11, BE20, BE30	2

8. Put the rubber sealing collar back in place and re-install the dismantled parts.



1.5 Technical data

1.5.1 Work done, working air gap, braking torques

If you use encoders/brakes with functional safety, the values for the maximum working air gaps and the work done until maintenance are reduced. For the new values, refer to the "Safety-Rated Encoders – Functional Safety for AC Motors DR.71–225, 315" addendum to the operating instructions.

Brake Type	Work done until maintenance [10 ⁶ J]	Working air gap [mm]		Brake disk [mm]	Part number damping plate/pole sheet	Braking torque settings					
		min. ¹⁾	max.			min.	Braking torque [Nm (lb-in)]	Type and number of brake springs			Order number of brake springs
							Standard	Blue	White	Standard	Blue/white
BE05	120	0.25	0.6	9.0	1374 056 3	5.0 (44) 3.5 (31) 2.5 (22) 1.8 (16)	3 – – –	– 6 4 3	– – – –	0135 017 X	1374 137 3
BE1	120	0.25	0.6	9.0	1374 056 3	10 (88.5) 7.0 (62) 5.0 (44)	6 4 3	– 2 –	– – –	0135 017 X	1374 137 3
BE2	180	0.25	0.6	9.0	1374 019 9	20 (177) 14 (124) 10 (88.5) 7.0 (62) 5.0 (44)	6 2 2 – –	– 4 2 4 3	– – – – –	1374 024 5	1374 052 0
BE5	390	0.25	0.9	9.0	1374 069 5	55 (487) 40 (354) 28 (248)	6 2 2	– 4 2	– – –	1374 070 9	1374 071 7
						20 (177) 14 (124)	– –	– –	6 4		1374 773 8
BE11	640	0.3	1.2	10.0	1374 171 3	110 (974) 80 (708) 55 (487) 40 (354) 28 (248)	6 2 2 – –	– 4 2 4 3	– – – – –	1374 183 7	1374 184 5
					1374 171 3 + 1374 699 5	20 (177)	–	–	4	1374 183 7	1374 778 9
BE20	1000	0.3	1.2	10.0	–	200 (1770) 150 (1328) 110 (974) 80 (708) 55 (487)	6 4 3 3 –	– 2 3 – 4	– – – – –	1374 322 8	1374 248 5
					1374 675 8	40 (354)	–	3	–		
BE30	1500	0.3	1.2	10.0	–	300 (2655) 200 (1770) 150 (1328) 100 (885) 75 (667)	8 4 4 – –	– 4 – 8 6	– – – – –	0187 455 1	1374 435 6

1) When checking the working air gap, note: Parallelism tolerances on the brake disk may cause deviations of ± 0.15 mm after a test run.



The following table shows the brake spring layout:

BE05 – BE11:					
6 springs	3 + 3 springs	4 + 2 springs	2 + 2 springs	4 springs	3 springs
BE20:					
6 springs	4 + 2 springs	3 + 3 springs	4 springs	3 springs	
BE30:					
8 springs	6 + 2 springs	4 + 4 springs	6 springs	4 springs	



SEW-EURODRIVE
Driving the world

SEW
EURODRIVE

SEW-EURODRIVE GmbH & Co KG
P.O. Box 3023
D-76642 Bruchsal/Germany
Phone +49 7251 75-0
Fax +49 7251 75-1970
sew@sew-eurodrive.com

→ www.sew-eurodrive.com